

HOT FLOW PRESSURE MAP OF A VACUUM FACILITY AS A FUNCTION OF FLOW RATE TO STUDY FACILITY EFFECTS**†

Mitchell L.R. Walker‡
mwalker@engin.umich.edu

Alec D. Gallimore§
alec.gallimore@umich.edu

Plasmadynamics and Electric Propulsion Laboratory
Phone: 734-764-5229
Fax: 734-763-7158

Department of Aerospace Engineering
University of Michigan
College of Engineering
Ann Arbor, MI 48109 USA

ABSTRACT

A neutral background pressure map of the Large Vacuum Test Facility (LVTF) at the University of Michigan is presented. The LVTF was mapped at hot anode (i.e., discharge on) flow rates of 5.25 and 10.46 mg/s, corresponding to P5 Hall thruster operating conditions of 1.5 and 3.0 kW. The chamber pressure was mapped at nominal xenon pumping speeds of 140,000 and 240,000 l/s, corresponding to base pressures of 1.3×10^{-6} Torr and 7.3×10^{-7} Torr, respectively. The pressure map was performed with a rake consisting of five calibrated Bayard-Alpert (BA) hot-cathode ionization gauges. Analysis of axial pressure profiles on the LVTF's centerline shows that the plume pressure decreases from a maximum at the thruster exit plane down to the facility background pressure at approximately 2 m downstream of the exit plane. In addition, a neutral gas background pressure map of Vacuum Facility 12 (VF-12) at the NASA Glenn Research Center is presented. VF-12 was mapped at a series of cold anode flow rates corresponding to P5 Hall thruster operating conditions of 1.5, 3.0 and 9.0 kW. The chamber pressure was mapped at a nominal xenon pumping speed of 282,000 l/s with a rake consisting of the same five BA hot-cathode ionization gauges used in the LVTF. The cold flow pressure in VF-12 rapidly decreases out to approximately 2 m downstream of the thruster exit plane. From this point, the pressure slowly, but continually drops as the cryosurfaces are approached. Cryopump location affects the neutral density gradients within a vacuum facility and should be carefully considered when analyzing plume and performance data or designing a new Hall thruster facility. The hot flow neutral density profiles of each facility will be used to help correct performance and plume measurements for facility effects.

Introduction

It is technically challenging and expensive to create the on-orbit environment in a ground-based laboratory facility. All ground-based vacuum facilities possess a low-density background neutral gas due to physical pumping limitations and the leak rate of the facility. As gas is introduced into

the vacuum chamber in the form of propellant, the background pressure rises until the pumping speed, facility leak rate, and propellant flowrate equilibrate for the operating condition.

The facility background gas present in the vacuum chamber can distort the exhaust plume of the thruster.¹ High-energy

* Presented as Paper IEPC-03-0077 at the 28th International Electric Propulsion Conference, Toulouse, France, 17-21 March 2003

† Copyright © 2003 by Mitchell Walker. Published by the Electric Rocket Propulsion Society with permission.

‡ Graduate Student, Aerospace Engineering

§ Associate Professor, Aerospace Engineering and Applied Physics

exhaust particles interact with the neutral background particles through charge exchange collisions (CEX).² In the plume, the effects of CEX products are most evident in the perimeter, where they lead to an increase in the measured current density. Thruster operation and performance are dependent on the background pressure of the facility.³ At elevated background pressures, residual gas particles can be entrained into the thruster discharge region artificially increasing engine thrust. Elevated facility pressure has also been found to increase the width of the ion energy distribution function through elastic collisions between beam ions and neutral background particles.⁴

Due to these effects, the validity of comparisons made between data taken in facilities with different background pressures, especially at 10^{-4} Torr and higher, is questionable. However, comparisons have been made between data taken in Russia and at NASA.⁵ In order to correlate data taken in ground based facilities to in-space thruster performance, the effect of facility background pressure on thruster operation must be fully characterized and taken into account when analyzing test data. Because of the drastic implications of facility effects, electric propulsion technology has reached the point where standard guidelines must be developed for test facilities to ensure reliable engine development and testing.⁵ This need has become even more pressing now that 50+ kW Hall thrusters are being developed.⁶

Several investigations are underway to numerically model thruster performance and the interactions between Hall thrusters and spacecraft.^{7,8} The results of these models are highly dependent on experimentally measured boundary conditions. One of the most important auxiliary inputs required by these codes is background pressure of a laboratory vacuum chamber.⁷

The University of Michigan's Plasmadynamics and Electric Propulsion Laboratory (PEPL) has launched an investigation of facility effects introduced by elevated backpressures. This investigation has thus far included measuring the performance of the P5 Hall Effect Thruster at different pumping speeds,⁹ evaluating a collimated Faraday probe's ability to filter out CEX ions while measuring the ion current density at elevated back pressures,^{2,10} comparing NASA Glenn Research Center's (GRC) and Jet Propulsion Laboratory's (JPL) nude Faraday probes¹¹, and mapping the cold** flow pressure of the Large Vacuum Test Facility (LVTF)¹², which was the first step in creating a technique for making neutral density pressure maps with hot flow in a Hall thruster facility.

** Throughout the paper, we use the phrase "cold flow" to denote xenon flowing through the thruster anode and cathode without a plasma discharge and "hot flow" to denote xenon flowing through the anode and cathode of a thruster in operation.

The objective of the experiments presented in this paper is to demonstrate a technique for making neutral density pressure maps with hot flow in a vacuum facility. The results of the hot flow pressure maps will then be compared to numerical simulations of the chamber in order to develop the tools that will be necessary to correct for facility effects.

In the following, we explain the experimental apparatus, present the experimental results, and discuss the experimental results. Finally, some conclusions and directions for future work are offered.

Experimental Apparatus

The experiments presented in this paper were conducted in PEPL's LVTF and in NASA GRC's VF-12. The University of Michigan facility will be described first, followed by the NASA GRC facility.

PEPL Vacuum Facility

Experiments at PEPL were conducted in the LVTF. The P5 was mounted at thruster station 1, as indicated in Figure 1. The LVTF is a stainless steel clad vacuum chamber that has a diameter of 6 m and a length of 9 m. Two 2,000 CFM blowers and four 400 CFM mechanical pumps evacuate the LVTF to moderate vacuum (30 - 100 mTorr). To reach high vacuum the LVTF is equipped with seven CVI TM-1200 re-entrant cryopumps, each of which is surrounded by a LN₂ baffle. The combined pumping speed of the facility is 500,000 l/s on air, and 240,000 l/s on xenon with a base pressure of 2.5×10^{-7} Torr. The cryopump system can be operated with any number of pumps in use. For the experiments reported here, the LVTF was operated with four and seven cryopumps with average anode flow rates of 5.25 and 10.46 mg/s, both with a 0.60 mg/s cathode flow. At the nominal xenon pumping speeds of 140,000 l/s and 240,000 l/s, the operating pressures of the LVTF were approximately 9.2×10^{-6} and 1.5×10^{-5} Torr on xenon with 4 pumps and 5.4×10^{-6} and 8.8×10^{-6} Torr on xenon with 7 pumps, as shown in Table 1.

Chamber pressure was monitored by two hot-cathode ionization gauges, as indicated in Figure 1. The first gauge is a Varian model 571 Bayard-Alpert (BA) gauge with a HPS model 919 Hot Cathode Controller. The BA model 571 ionization gauge is connected to the chamber via a 25-cm-long, by 3.48-cm-inner-diameter, tube. The second is a Varian model UHV-24 nude gauge with a Varian UHV senTorr Vacuum Gauge Controller. This unit was calibrated on air by the manufacturer. Pressure measurements from both gauges were corrected for xenon using the known base pressure on air and a correction factor of 2.87 for xenon according to the following equation¹³

$$P_c = \frac{P_i - P_b}{2.87} + P_b, \quad (1)$$

where P_c is the corrected pressure on xenon, P_b is the base pressure, and P_i is the indicated pressure when xenon is flowing into the vacuum chamber. The corrected pressure of the nude gauge is reported as the chamber background pressure since the nude gauge agreed with the far-field cold flow pressures in Ref. 12. All pumping speeds and pressures reported in the following are corrected for xenon.

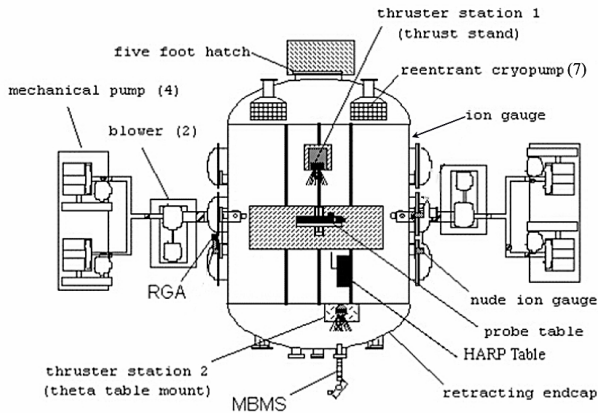

Figure 1 – Schematic of the LVTF.

Hall Thruster

All experiments at the University of Michigan were performed on the P5, a laboratory-model Hall thruster. The P5 has a mean diameter of 148 mm, a channel width of 25 mm, a channel depth of 38 mm, and has a nominal power rating of 5 kW.⁹ A more detailed description of the P5 can be found in Ref. 14.

A LaB₆ laboratory model cathode was located at the 2 o'clock position on the thruster, looking upstream. The cathode orifice was located approximately 30 mm downstream from the outer front pole piece.

High-purity (99.999% pure) xenon propellant was supplied to the Hall thruster from compressed gas bottles through stainless-steel feed lines. MKS 1179JA mass flow controllers metered the anode and cathode propellant flows. The flow controllers were calibrated with a custom apparatus that measures gas pressure and temperature as a function of time in an evacuated chamber of known volume. The mass flow controllers have an accuracy of $\pm 1\%$ full scale.

NASA GRC Vacuum Facility 12

Experiments at NASA GRC were conducted in VF-12. The P5-2 (also known as the NASA-173Mv.1) was mounted on the chamber centerline with the exit plane 1.25 m downstream of the rear door, as indicated in Figure 2. VF-12 has a diameter of 3 m and a length of 9 m and is

equipped with a liquid helium cryopanel surface with a pumping speed in excess of 1,000,000 liters per second on air and 282,000 l/s on xenon. A 1000 l/s (air) turbo pump, located on top of the chamber, evacuates non-condensable gases. At the average anode flow rates investigated—5.25, 10.46, and 14.09 mg/s, all with a 0.60 mg/s cathode flow—and at a nominal xenon pumping speed of 282,000 l/s, the operating pressures of VF-12 were approximately 3.0×10^{-6} , 5.0×10^{-6} , 6.7×10^{-6} Torr on xenon, as shown in Table 2.

Chamber pressure was monitored by two hot-cathode ionization gauges, as indicated in Figure 2. The corrected main gauge reading is normally reported as the facility background pressure. The turbo ionization gauge, located near the turbo pump, is not considered when reporting the facility pressure. Pressure measurements from the main gauge were corrected for xenon using the known base pressure on air and a correction factor of 2.87 for xenon according Equation 1. All pumping speeds and pressures reported in the following are corrected for xenon.

Table 1 – P5 Hot Flow pressure map operating conditions.

Discharge Voltage (V)	Discharge Current (A)	Anode Flow (mg/s)	Cathode Flow (mg/s)	Nominal Pumping Speed (l/s)	Chamber Pressure (Torr-Xe)
300	5.22	5.25	0.60	140,000	6.1E-06
300	11.4	10.46	0.60	140,000	9.2E-06
300	5.12	5.25	0.60	240,000	3.8E-06
300	11.1	10.46	0.60	240,000	5.7E-06

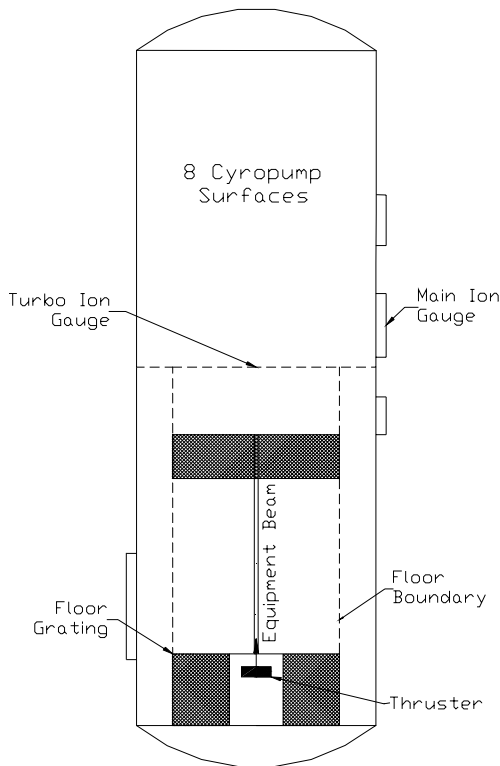

Figure 2 – Schematic of VF-12.

Hall Thruster

All experiments at NASA GRC were performed with the NASA-173Mv.1 5 kW laboratory-model Hall thruster. The NASA-173Mv.1 has a mean diameter of 148 mm, a channel width of 25 mm, and has a nominal power rating of 5 kW. A more detailed discussion of this thruster can be found in Ref. 15. This thruster is designed to operate in both single- and two-stage modes. For these experiments, the electrode used for two-stage operation was replaced with the same ceramic used in the chamber walls, enabling the engine to be operated as a single-stage device.

A NASA GRC laboratory-model hollow cathode was located at the 12 o'clock position on the thruster. The cathode orifice was located approximately 25 mm downstream and 25 mm radially away from the outer front pole piece at an inclination of 30° from the thruster centerline. Xenon flow rates corresponding to the necessary flow rates, shown in Table 2, of the operating NASA-173Mv.1 Hall thruster were sent through the cathode. This will yield comparable backpressures for future pressure maps with the operating NASA-173Mv.1 Hall thruster.

Xenon propellant was supplied to the thruster using a rack-configured xenon propellant feed system. Anode and cathode propellant flows were controlled and monitored with Unit Model 1160 Metal ZSeal™ mass flow

controllers. The flow controllers were calibrated with a custom apparatus similar to that used at PEPL.

Ionization Gauge

The BA hot-cathode ionization gauge accurately measures pressure over the range of 10^{-4} to 10^{-12} Torr. This gauge was used to perform the cold flow and we will now use it for the hot flow. More detailed information on selection of this gauge can be found in Ref. 12.

Five Varian 571 BA type standard range ionization gauge tubes were used to measure the chamber pressure field in both the LVTF and VF-12. In the LVTF, a pressure map of the chamber will be taken with the thruster operating. Thus, the BA gauges need a neutralizer to ensure that the plasma does not affect pressure measurements. The neutralizer design prevents plume ions from having a direct line of sight to the ionization gauge filament. The neutralizer contains two 72 mesh screens (0.5 by 0.5 mm and 1.0-mm-thick). The screens ensure neutralization of any ions that travel inside the orifice and those that are not neutralized by wall collisions. Figure 3 shows the Varian 571 BA ionization gauge and the neutralizer along with their mounting position with respect to the anode flow direction.

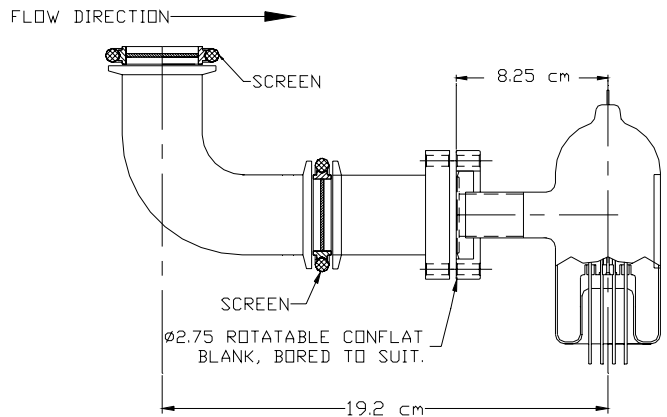

Figure 3 – Schematic of the Varian 571 BA Ionization Gauge connected to the neutralizer.

The outer screen of the neutralizer, located in the horizontal plane of the chamber centerline, is in direct contact with the plasma for the hot flow pressure maps. To avoid disturbing the ionization gauge pressure measurements the outer screen was electrically isolated from the rest of the neutralizer, so that the screen floated. A bias voltage study on the outer screen, presented in a later section, was performed to validate this configuration.

Two of the BA gauges were controlled by separate Varian senTorr gauge controllers. The remaining three BA gauges were controlled by a Varian Multi-Gauge controller. The Multi-Gauge controller simultaneously controlled each of

the three BA gauges and allowed the user to scroll through a display of the pressure for each gauge.

Ionization Gauge Calibration

Calibration of the five ionization gauge systems was performed by the Helium Leak Testing Incorporated Calibration Laboratory. Each system, comprising of a BA gauge, the actual internal and external cables used in the LVTF and VF-12 mapping, a Varian 10-wire vacuum chamber instrumentation feedthrough, and a Varian BA circuit board mounted in either the senTorr or Multi-Gauge controller, was calibrated with xenon as a one-piece unit using a National Institute of Standards and Technology traceable Leybold-Heraeus Viscovac VM211 spinning rotor viscosity gauge.

LVTF Ionization Gauge Positioning System

To generate the two-dimensional mapping inside the LVTF, the ionization gauges were mounted to a custom built, two-axis positioning stage developed by New England Affiliated Technologies. The positioning system is composed of a 1.8-m-long linear stage in the radial direction that is mounted on a 0.9-m-long axial stage with an absolute linear position accuracy of 0.15 mm. A LabView VI controlled the motion of the two linear position tables, which in turn moved the Ionization Gauge Positioning System (IGPS) that carried the five BA gauges used to survey the chamber. Figure 4 shows a schematic of the IGPS mounted within the LVTF. The IGPS allowed the pressure measurements to be taken throughout the majority of the chamber with a single evacuation cycle of the LVTF. The region mapped by the IGPS covers an area with a minimum distance from the thruster of 0.5 m, encompassing the typical 1 m distance at which plume properties are measured.

Figure 5 displays the IGPS mounted in the LVTF and the 25 cm X 25 cm grid on which data points were taken. The solid circles indicate the position of each of the five probes when the IGPS is in the initial position. The note in Figure 5 denotes that gauge 2 is positioned on the opposite side of the chamber centerline to confirm that possible wake effects generated off the gauges were not interfering with downstream probes. Figure 4 also shows the coordinate system used for this experiment. The coordinate system origin is located at the discharge chamber exit plane on the thruster centerline, where negative X is to the left and positive Y is up the page.

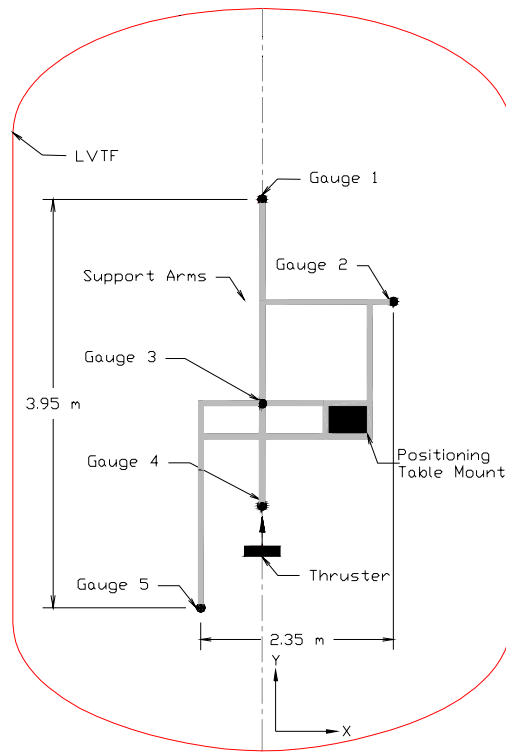

Figure 4 – Schematic of the IGPS mounted in the LVTF.

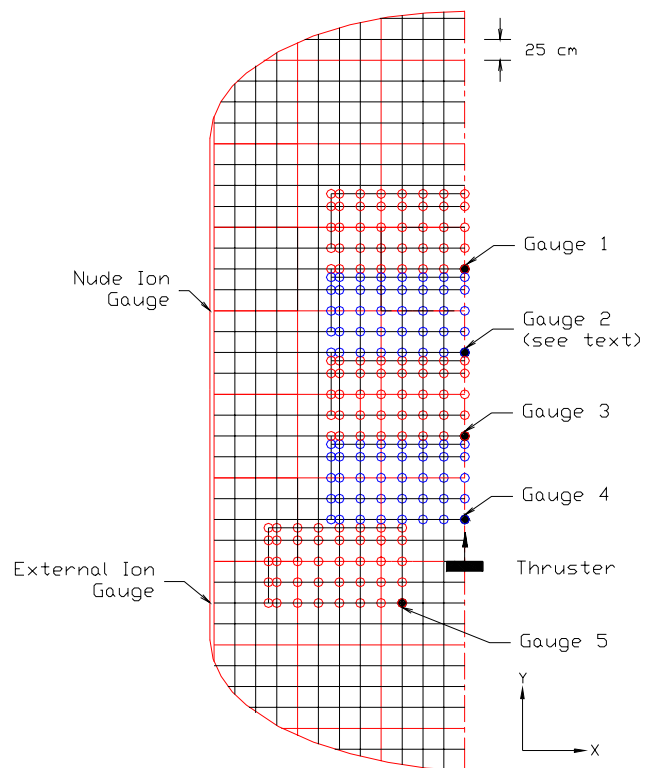

Figure 5 – LVTF half-plane (looking down) with the IGPS and a 25 cm X 25 cm grid. Each open circle denotes the location of a data point.

VF-12 Ionization Gauge Positioning System

To generate the two-dimensional mapping inside VF-12, the ionization gauges were mounted to a two-axis positioning system developed by Parker Daedal. The positioning system is composed of a 0.6-m-long linear stage in the radial direction that is mounted on a 0.9-m-long axial stage with an absolute linear position accuracy of 0.01 mm. A LabView VI controlled the motion of the two linear position tables, which in turn moved the IGPS that carried the five BA gauges used to survey the chamber. Figure 6 shows a schematic of the IGPS mounted within VF-12. The IGPS allowed the pressure measurements to be taken throughout the majority of the chamber with a single evacuation cycle of VF-12. The region mapped by the IGPS covers an area with a minimum distance from the thruster of 0.5 m, encompassing the typical 1 m distance plume properties are measured.

Figure 7 displays the 25 cm X 25 cm grid in VF-12 on which data points were taken. The solid circles indicate the position of each of the five probes when the IGPS is in the initial position. Figure 7 also shows the coordinate system used for this experiment. The coordinate system origin is located at the discharge chamber exit plane on the thruster centerline, where negative X is to the left and positive Y is up the page.

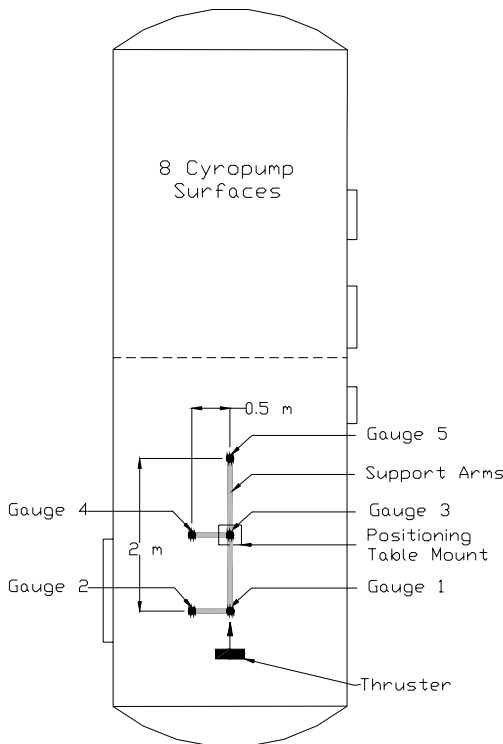

Figure 6 – Schematic of the IGPS mounted in VF-12.

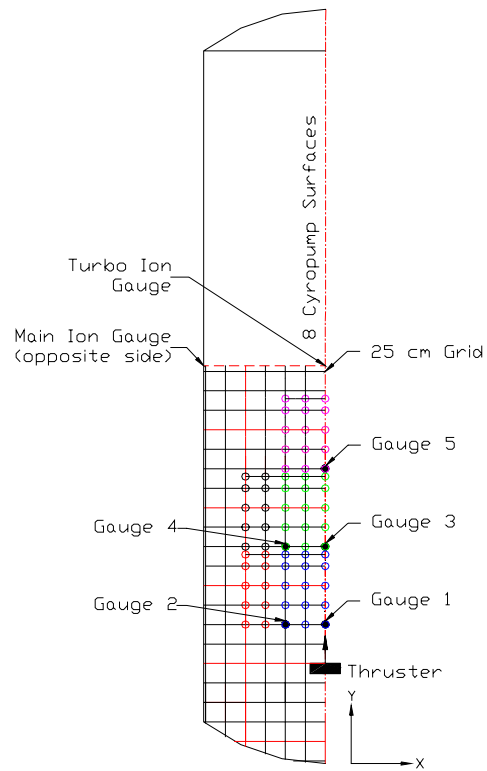

Figure 7 – VF-12 half-plane (looking down) with the IGPS and a 25 cm X 25 cm grid. Each open circle denotes the location of a data point.

Experimental Results

To operate the BA gauges on the IGPS, a custom set of cables were constructed. These cables pass through the chamber wall on the five, 10-wire instrumentation feedthroughs. The overall cable lengths from controller to BA gauge were approximately 15 and 23 m, depending on the location of the particular gauge. To verify the operation of each line after the setup was complete, a sealed-glass ionization gauge was operated with a senTorr controller. Varian reports that the reference ionization tube is sealed-off at less than 5.0×10^{-6} Torr. Each of the ionization gauge systems measured pressures below the maximum pressure reported by the vendor. This test confirmed the operation of the equipment while the facility was at atmosphere to avoid unnecessary evacuation cycles of the vacuum chamber. The BA gauges mounted to the IGPS measured pressures within a few percent of the pressure reported on the gauges used to monitor facility background pressure. This comparison confirmed that the ionization gauges mounted on the IGPS were operating properly at vacuum.

In a previous experiment we created a cold flow pressure map of the LVTF with the same ionization gauges and neutralizers used in the experiments presented in this paper. During that study, we determined that the neutralizer conductance does not noticeably affect the time response of the internal ionization gauges.¹²

We assumed that chamber pressure was horizontally symmetric about the chamber centerline in the LVTF and VF-12. This assumption reduced the number of spatial positions that had to be mapped. All pressure map data presented will only be from one side of a chamber.

For the hot flow pressure maps, the BA ionization gauge is immersed in plasma. To minimize the effect of charged particles on the pressure measurements, an outer screen bias voltage study was performed using the P5 in the LVTF. The outer screen was electrically isolated from the neutralizer and a biasing wire was connected to the screen so that it could be floated, grounded, or biased to a particular voltage. This configuration allows the screens to repel or attract the charged particle species. The biasing wire was connected to a power supply outside of the chamber and a current shunt was used to measure the amount of current being collected or emitted in each electrical configuration.

First, the effects of biasing, grounding, and floating the outer screen on the measured pressure were investigated, i.e., does merely biasing the outer screen with no plasma present affect the behavior of charge particles within the gauge, thus affecting the pressure measured. This study was performed on gauge 1 with no flow through the thruster. The measured pressure was unaffected by floating, grounding, and biasing the outer screen. Since there was no plasma present, the outer screen collected no current for the above configurations, indicating that particles within the ionization gauge were not being collected by the biased outer screen.

Next, the same procedure was performed with the P5 operating at 300 V and 5.4 A. For this study gauge 3 was monitored at a position 1.5 m downstream of the thruster exit plane and on the thruster centerline. The gauge pressure and current collected were recorded for each of the electrical configurations.

Figure 8 shows the results of the bias voltage study. Initially, the outer screen was floated and the pressure measurement was unaffected. Next, the outer screen was biased from -20 V to 50 V in 5 V increments. At increasingly negative bias voltages the indicated pressure increased slightly. This may be a result of attracting additional ions into the gauge, which increased the current collected by the gauge filament. The gauge then indicated a higher pressure. In the grounded configuration, the indicated pressure was negligibly affected. As the bias voltage became increasingly positive, the indicated pressure began to rise and a large amount of current was collected by the outer screen. The positively biased screen attracted a large number of electrons to the neutralizer screen resulting in the increased ionization of neutrals within the gauge. The gauge filament then collected the additional ions, increasing the indicated pressure. In the floating

configuration, gauge 3 measured 3.1×10^{-5} Torr-Xe and the outer screen collected 0.2 mA. This study confirmed that floating the outer screen for the hot flow pressure map does not affect the performance of the ionization gauges.

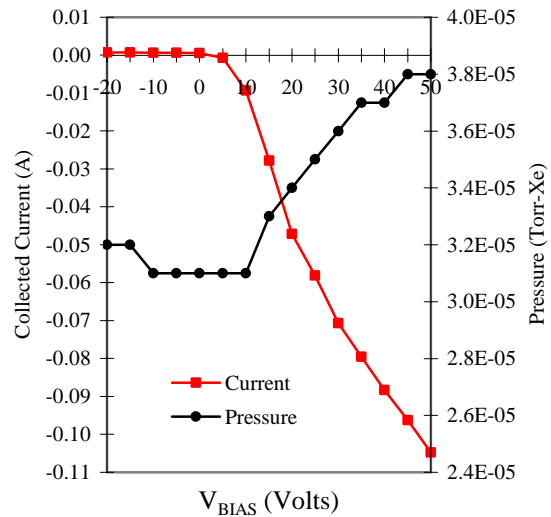

Figure 8 – Outer Screen Bias Voltage Study

University of Michigan

Table 1 presents the thruster and chamber operating conditions that were investigated and the average pressures measured with the nude and external gauges. The chamber pressure was mapped at P5 thruster operating conditions of 300 V, at approximately 5 and 11 A, corresponding to flow rates of 5.25 and 10.46 mg/s. The hot flow pressure maps were created at nominal facility pumping speeds of 140,000 and 240,000 l/s.

Figures 9 - 12 present the hot flow pressure map data recorded in the LVTF. We were unable to acquire data with ionization gauge 5 for the hot flow pressure maps. This is because the pressure in the area interrogated by ionization gauge 5 was above the controller’s maximum allowable pressure, thus causing the gauge to automatically shut down.

Hot flow pressure maps were not created for anode flow rates above 10.46 mg/s. The flow rate limit is created by the pressure downstream of the thruster being high enough to exceed controller 3’s shut down pressure limit. It is possible to override the shut down pressure of the ionization controller. However, if the ionization gauge is operated at “high” pressures, the gauge may be damaged. Therefore, the automatic shut down pressure limits were left operational for these experiments. This was not expected given our cold flow results.

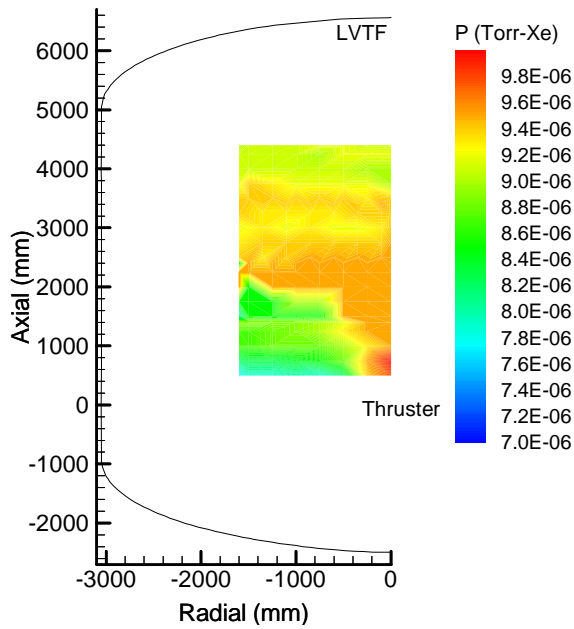

Figure 9 – Hot flow pressure map of the LVTF with an anode flow rate of 5.25 mg/s and a cathode of 0.60 mg/s, at a nominal pumping speed of 140,000 l/s. The nude gauge measured 6.1×10^{-6} Torr, corrected for xenon. (300 V, 5.22 A thruster operation)

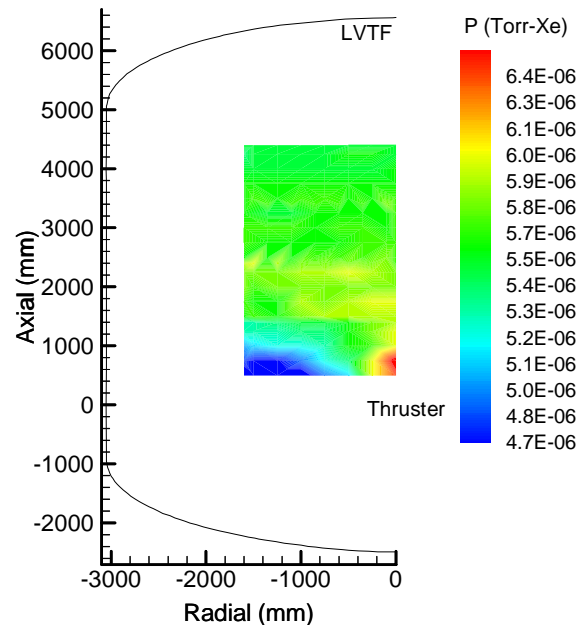

Figure 11 – Hot flow pressure map of the LVTF with an anode flow rate of 5.25 mg/s and a cathode of 0.60 mg/s, at a nominal pumping speed of 240,000 l/s. The nude gauge measured 3.8×10^{-6} Torr, corrected for xenon. (300 V, 5.72 A thruster operation)

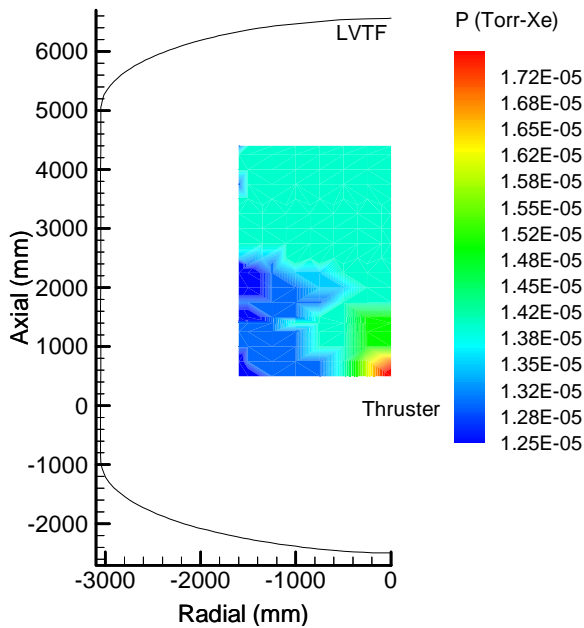

Figure 10 – Hot flow pressure map of the LVTF with an anode flow rate of 10.46 mg/s and a cathode flowrate of 0.60 mg/s, at a nominal pumping speed of 140,000 l/s. The nude gauge measured 9.2×10^{-6} Torr, corrected for xenon. (300 V, 11.4 A thruster operation)

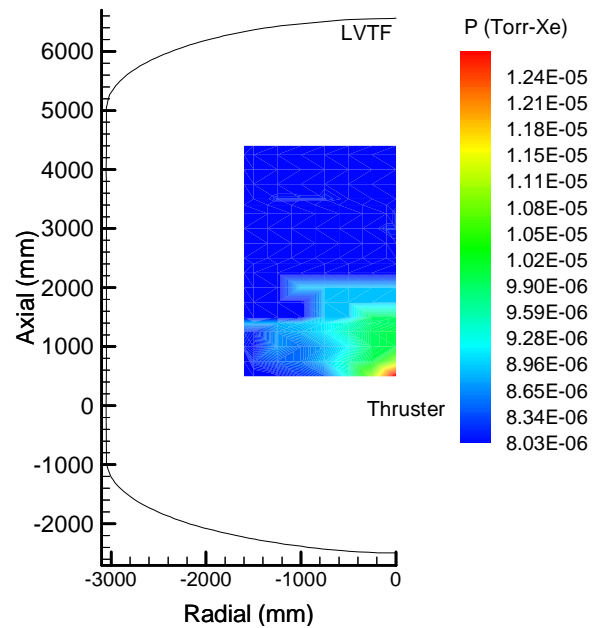

Figure 12 – Hot flow pressure map of the LVTF with an anode flow rate of 10.46 mg/s and a cathode flow rate of 0.60 mg/s, at a nominal pumping speed of 240,000 l/s. The nude gauge measured 5.7×10^{-6} Torr, corrected for xenon. (300 V, 11.1 A thruster operation)

NASA GRC

Table 2 presents the thruster flow rates and nominal pumping speed that were investigated in VF-12 and the pressures measured with the main ionization gauge. The facility base pressure was 1.9×10^{-7} Torr. Initially, the chamber background pressure was mapped with zero propellant flowrate into the chamber to evaluate the chamber base pressure. Then the chamber pressure was mapped at average anode flowrates of 5.25, 10.46, and 14.09 mg/s at a nominal facility pumping speed 282,000 l/s.

Figures 13 - 15 present the cold flow pressure map data. Figure 16 shows the 5.25 mg/s hot flow pressure map taken with a grounded outer screen.

Table 2 – P5-2 Cold Flow operating conditions.

Anode Flow (mg/s)	Cathode Flow (mg/s)	Nominal Pumping Speed (l/s)	Main Pressure (Torr-Xe)
5.25	0.60	282,000	3.0E-06
10.46	0.60	282,000	5.0E-06
14.09	0.60	282,000	6.7E-06

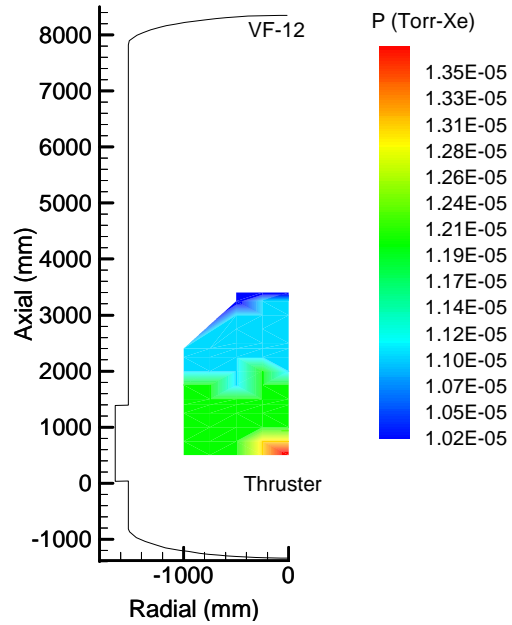

Figure 14 – Cold flow pressure map of the VF-12 with an anode flow rate of 10.46 mg/s and a cathode flowrate of 0.60 mg/s, at a nominal pumping speed of 282,000 l/s. The Main gauge measured 5.0×10^{-6} Torr, corrected for xenon.

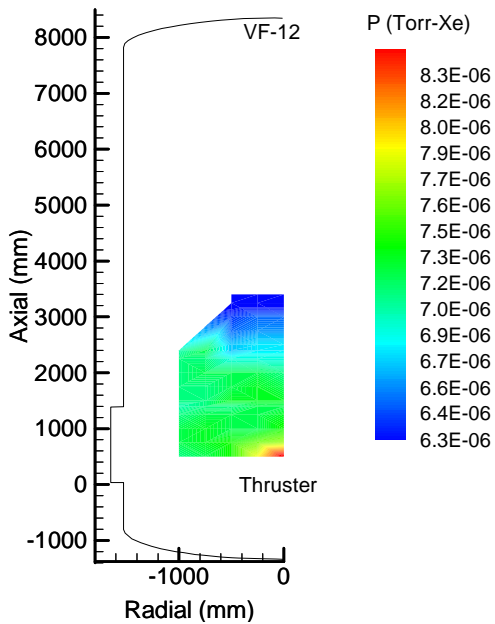

Figure 13 – Cold flow pressure map of the VF-12 with an anode flow rate of 5.25 mg/s and a cathode flowrate of 0.60 mg/s, at a nominal pumping speed of 282,000 l/s. The Main gauge measured 3.0×10^{-6} Torr, corrected for xenon.

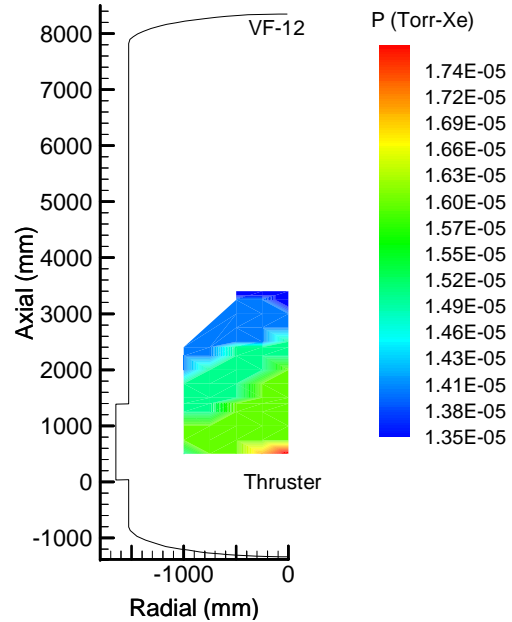

Figure 15 – Cold flow pressure map of the VF-12 with an anode flow rate of 14.09 mg/s and a cathode flowrate of 0.60 mg/s, at a nominal pumping speed of 282,000 l/s. The Main gauge measured 6.7×10^{-6} Torr, corrected for xenon.

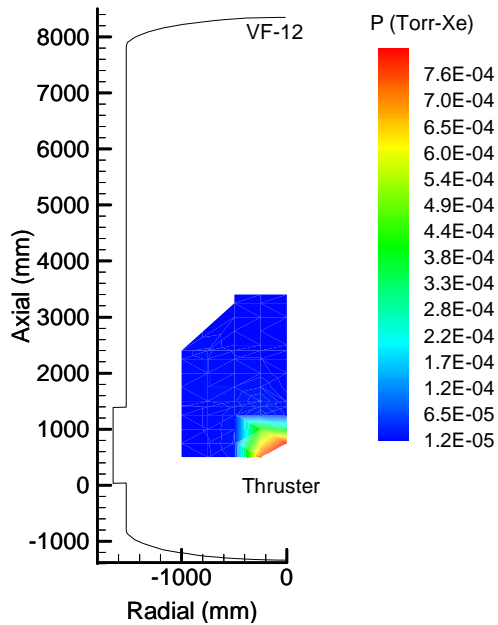

Figure 16 – Hot flow pressure map of the VF-12 with an anode flow rate of 5.25 mg/s and a cathode flowrate of 0.60 mg/s, at a nominal pumping speed of 282,000 l/s. The Main gauge measured 2.9×10^{-6} Torr, corrected for xenon. (300 V, 4.64 A thruster operation)

Discussion

The pressure maps for the hot and cold flow differ by a factor of approximately two in both the LVTF and VF-12 for identical flow rates and pumping speeds. The increase in indicated pressure is caused by the gauge filament collecting more current in the hot flow case. The increase in current may be the effect of inadequate filtering of ions by the neutralizer screens. A grid opening much larger than a few Debye lengths would not allow the sheaths to merge. Therefore, repulsion of beams ions would not occur near the grid opening centerline, which allows beams ions to travel into the ionization gauge and be collected by the filament. The Debye length was calculated with data previously taken in the P5 plume using a Langmuir probe. The electron number density, n_e , and electron temperature, T_e , are approximately $7.5 \times 10^{10} \text{ cm}^{-3}$, and 1.6 eV 1 m downstream of the P5 exit plane.¹⁴ This yields a Debye length of 0.034 mm. The screen opening is 0.5 mm by 0.5 mm, which would require a sheath thickness of approximately 7 Debye lengths for the sheaths to merge. Away from the thruster centerline and exit plane, the Debye length increases due to the decrease in electron number density. A longer Debye length ensures that the sheaths have merged, which makes it less likely for ions to enter the gauge. Thus, the ion filter is more effective the farther the gauge is from the thruster exit.

In spite of the difference in magnitude, comparisons between the hot and cold flow pressure profile trends may still be made. Analysis of axial pressure profiles on chamber centerline show that the plume pressure decreases from a maximum at the thruster exit plane to a pressure about 1.5 times higher than the facility background pressure by approximately 2 m downstream of the exit plane. Analysis of axial pressure profiles on the LVTF centerline also show that increasing the mass flow rate increases the pressure immediately downstream of the anode. For both flowrates, the plume has expanded to the chamber operating pressure at approximately 2.0 m downstream of the anode. As the flowrate increases, the pressure gradient in the plume increases, but the length of the plume expansion to the chamber background pressure remains constant. This trend was seen for both flowrates. Increasing the pumping speed lowers the magnitude of the pressure, while the behavior of the axial pressure profile remains unaffected.

Normally, the base pressure of VF-12 is reported as the pressure indicated on the main ionization gauge located on the side of the chamber, as shown in Figure 2. The main ionization gauge connects directly to the chamber, yielding a negligible reduction in pumping speed from conductance. This method yields a reported base pressure of 1.9×10^{-7} Torr for the zero anode flow rate cold pressure map. For the zero flow condition the main gauge is an overestimate of the chamber background pressure. Yet, for the non-zero anode cold flow rates the main gauge underestimates the lowest pressure recorded during the pressure map. A pressure map with zero propellant was taken, but is not presented.

Figures 13 - 15 present the cold flow pressure maps created in VF-12. The axial centerline profile for the zero flow rate pressure map shows the chamber back pressure continuously drops from 0.5 m to 3.4 m downstream of the exit plane. This agrees with the physical configuration of the facility since the 8 cryosurfaces are located downstream of the thruster exit plane, as can be seen in Figure 2. The same behavior is present in the centerline axial profiles for anode flow rates of 5.25, 10.46, and 14.09 mg/s. The pressure rapidly decreases out to approximately 2 m downstream of the thruster exit plane. From this point, the pressure slowly, but continually drops as the cryosurfaces are approached.

Axial chamber centerline pressure profiles of VF-12 show that increasing the anode flowrate increases the magnitude of the background pressure. Also, as the anode flowrate increases the pressure gradient near the thruster exit plane increases. The distance that it takes for the plume to expand down to the VF-12 background pressure appears to be independent of flow rate. These same trends were observed in the LVTF cold flow pressure maps.¹²

After the VF-12 cold flow pressure maps were taken at NASA GRC, we decided to take a preliminary hot flow pressure map. The outer screen bias voltage study had not been conducted at this point, so the screens were grounded. The bias voltage study shows that a grounded screen has a negligible effect on the measured pressure and therefore the GRC hot flow pressure map should be valid. Figure 16 presents the hot flow pressure map taken in VF-12. The NASA-173Mv.1 was operating with an anode flowrate of 5.25 mg/s at 300 V and 4.52 A. The main ionization gauge indicated a facility pressure of 2.9×10^{-6} Torr-Xe with the thruster operating. The axial chamber centerline pressure profile shows that the pressure has dropped to a nearly constant level approximately 2 m downstream of the thruster exit plane. This is comparable to the characteristics seen in the LVTF hot flow pressure maps. Comparison of the VF-12, 5.25 mg/s hot and cold flow pressure maps shows that the hot flow pressure is approximately 2 orders of magnitude higher than the cold flow pressure map. The same phenomenon occurs in the LVTF cold flow to hot flow pressure map comparison, but to a much lesser degree.

The LVTF and VF-12 differ in physical geometry, i.e. the LVTF has a 3 m larger diameter. In both facilities, the distance it takes for the plume to expand to the background pressure for hot and cold is independent of flow rate. It appears that expansion distance is independent of chamber geometry for the physical size range between the LVTF and VF-12. For this experiment, we were unable to investigate the effect of pumping speed on the pressure maps in VF-12. Therefore, the effect of pumping speed in the LVTF cannot be compared to the effect of pumping speed in VF-12.

Cryopump location in a vacuum facility has a significant effect of the cold flow pressure map. Prior data taken in the LVTF show that for the zero anode flow rate condition, chamber back pressure clearly varies from a minimum just in front of the cryopumps to a maximum at the opposite end of the LVTF. This is explained by the cryopumps being mounted behind and above the thruster as can be seen in Figure 1. However in VF-12, the 8 cryosurfaces are located downstream of the thruster at the opposite end of the chamber. The zero flow axial chamber centerline profile shows that the background pressure decreases downstream of the exit plane. This behavior was also seen in the 5.25, 10.46, and 14.09 mg/s cold flow pressure maps of VF-12. Cryopump location affects neutral density gradients within a vacuum facility. Clearly, cryosurface location is a factor when analyzing plume and performance data or designing a new hall thruster facility.

Conclusions and Future Work

The goal of this work is to create a technique for calibrating a vacuum chamber in terms of pressure to account for elevated back pressures while testing Hall thrusters. A neutral gas background pressure map of the LVTF was

created at a series of hot anode flow rates corresponding to P5 Hall thruster operating conditions of 1.5, 3.0 kW. Analysis of the maps shows that the hot flow pressure maps are a factor of 2 greater than the cold flow pressure maps. The same behavior was observed between the hot and cold flow pressure maps acquired in VF-12 at 5.25 mg/s. Further investigation is necessary to reduce the amount of stray current collected by the ionization gauges operating in a hot flow. Axial pressure profiles on the thruster centerline indicate that the plume expands to about 1.5 times the LVTF background pressure in approximately 2.0 m. The plume expansion appears to be independent of anode flowrate and facility background pressure.

A neutral gas background pressure map of VF-12 was created at a series of cold anode flow rates corresponding to P5 Hall thruster operating conditions of 1.5, 3.0, and 9.0 kW. Analysis of the zero anode flowrate maps shows that for the zero flow condition the main gauge is an overestimate of the chamber background pressure. Yet, for the non-zero anode flow rates the main gauge is an underestimate of the lowest pressure recorded during the pressure map. Axial pressure profiles on the thruster centerline indicate that the plume expands to the facility background pressure in approximately 2.0 m. The plume expansion appears to be independent of anode flowrate. It appears that expansion distance is independent of chamber geometry for the physical size range between the LVTF and VF-12. Due to the ability of cryopump location to affect the neutral density gradients within the vacuum facility, cryosurfaces location should be carefully considered when analyzing plume and performance data or designing a new Hall thruster facility.

Acknowledgements

We would like to thank: Robert Jankvosky and Richard Hofer at NASA Glenn Research Center for use of Vacuum Facility 12, Keith Goodfellow of JPL for referring us to the Helium Leak Testing Incorporated Calibration Laboratory, and the departmental technical staff and other graduate students at PEPL for help in maintaining the facilities. This research was supported by the Air Force Office of Scientific Research grants F49620-00-1-0201 and F49620-01-1-0061 (Dr. Mitat Birkan is the contract monitor for both). In addition, Mr. Mitchell Walker is supported by the Michigan Space Grant Consortium and the National Science Foundation. The authors are greatly appreciative of this support.

References

1. King, L. B., Gallimore, A. D., "Ionic and Neutral Particle Transport Property measurements in the Plume of an SPT-100," 32nd Joint Propulsion Conference, Lake Buena Vista, FL, July 1-3, 1996.
2. Hofer, R. R., Walker, M. L. R., Gallimore, A. D., "A Comparison of nude and collimated Faraday Probes for Use with Hall Thrusters," IEPC-01-20, 27th International Electric Propulsion Conference, Pasadena, CA, Oct 14-19, 2001.
3. Manzella, D. H., Sankovic, J. M., "Hall Thruster Ion Beam Characterization," AIAA-95-2927, 31st Joint Propulsion Conference, San Diego, CA, July 10-12, 1995.
4. Gallimore, A. D., "Near- and Far-Field Characterization of Stationary Plasma Thruster Plumes," Journal of Spacecraft and Rockets, Vol. 38, No. 3, May-June 2001, pp 441-453
5. Semenkin, A., Kim, V., Gorshokov, O., Jankovsky, R., "Development of Electric Propulsion Standards – current status and further activity," IEPC-2001-070 27th International Electric Propulsion Conference, Pasadena, Oct. 15-19, 2001.
6. Jankovsky, R. S., Jacobson, D. T., Mason, L. S., Rawlin, V. K., Mantenieks, M. A., Manzella, D. H., Hofer, R. R., Peterson, P. Y., "NASA's Hall Thruster Program," AIAA-2001-3888, 37th Joint Propulsion Conference, Salt Lake City, UT, July 8-11, 2001.
7. Boyd, I. D., "Review of Hall Thruster Plume Modeling," Journal of Spacecraft and Rockets, Vol. 38, No.3, May-June 2001, pp. 381-387
8. Fife, J. M., Hargus, W. Jr, Jaworske, D. A., Sarmient, C., Mason, L., Jankovsky, R., Snyder, J. S., Malone, S., Haas, J., Gallimore, A., "Spacecraft Interaction Test Results of the High Performance Hall System SPT-140," AIAA-2000-3521, 36th Joint Propulsion Conference, Huntsville, AL, July 17-19, 2000.
9. Hofer, R. R., Peterson, P. Y., Gallimore, A. D., "Characterizing Vacuum Facility Backpressure Effects on the Performance of a Hall Thruster," IEPC-01-045, 27th International Electric Propulsion Conference, Pasadena, CA, Oct 14-19, 2001.
10. de Grys, K. H., Tilley, D. L., Aadland, R. S., "BPT Hall Thruster Plume Characteristics," AIAA-99-2283, 35th Joint Propulsion Conference, Los Angeles, CA, June 20-24, 1999.
11. Walker, M. L. R., Hofer, R. R., Gallimore, A. D., "The Effects of Nude Faraday Probe Design on the Measured Ion Current Density Profile of Hall Thruster Plumes," AIAA-2002-4253, 38th Joint Propulsion Conference & Exhibit, Indianapolis, IN, July 7-10, 2002.
12. Walker, M. L. R., Gallimore, A. D., "Pressure Map of a Facility as a Function of Flow Rate to Study Facility Effects," AIAA-2002-3815, 38th Joint Propulsion Conference, Indianapolis, IN, July 7-10, 2002.
13. Dushman, S., *Scientific Foundations of Vacuum Technique*, Vol. 4, Wiley, New York, 1958.
14. Haas, J. M., Gulczinski III, F. S., Gallimore, A. D., "Performance Characteristics of a 5 kW Laboratory Hall Thruster," AIAA-98-3503, 34th Joint Propulsion Conference, Cleveland, OH, July 12-15, 1998.
15. Hofer, R. R., Peterson, P. Y., Gallimore, A. D., "A High Specific Impulse Two-Stage Hall Thruster with Plasma Lens Focusing," 27th International Electric Propulsion Conference, Pasadena, CA, Oct 14-19, 2001.